

Saltfork Craftsmen Artist-Blacksmith Association

October 2009



Getting ready for the State Fair

**Saltfork Craftsmen
Artist-Blacksmith Association
Officers and Directors**

President: Gerald Franklin 580-467-8667
Rt. 3 Box 239J, Duncan, Ok 73533
franklin@myrhinomail.com

Vice-President/events: Bill Davis 580-549-6824
23966 NE Wolf Rd
Fletcher, Okla. 73541
lazyassforge@hughes.net

Sec-Treas. Mike George 580-327-5235
1227 4th St. Alva, Ok. 73717
mike-marideth@sbcglobal.net

Director/website: JC Banks 580-482-3209
16007 S. CR 206 Altus, Ok. 73521
jc.banks@okstate.edu

Director: Byron Doner 405-650-7520
6520 Alameda, Norman Okla.
byrondoner@earthlink.net

Director/swage blocks: Bill Kendall 918-742-7836
1756 E. 59th St Tulsa Ok. 74105
wwkendall@aol.com

Director: Richard Dyer 918-582-5065
1119 S Birmingham Pl. Tulsa, Ok. 74104
ironryer@aol.com

Assignments:

Editor: Diana Davis 580-549-6824
23966 NE Wolf Rd Fletcher, Ok 73541
Diana-copperrose@hughes.net

Librarian
Bill Malsom 918-440-4318
21450 N. 4020 Rd. Bartlesville, Ok 74006
billmalsom@hotmail.com
918-440-4318

Workshop Coordinator
David Seigrist 580-688-3555
dseigrist2004@yahoo.com

The Saltfork Craftsmen Artist-Blacksmith Association, a non-profit organization of amateur and professional artist and craftsmen, publishes this newsletter monthly. Our purposes are the sharing of knowledge, education and to promote a more general appreciation of the fine craftsmanship everywhere. We are a chapter of the Artist-Blacksmith Association of North America.

Material from this newsletter may be freely copied without permission for non-profit purposes. Please credit the author and this publication.

Visit our Saltfork Craftsmen Website:
www.saltforkcraftsmen.org

Trading Post

For Sale:
5/8in. Round 1045 stock in 12 ft. lengths. Price is .50/ft. contact Ron Lehenbauer at therustyanvil@yahoo.com or call 580-554-1126 to order. Delivery can be made at the Conference. I can have it cut into 1ft or 6ft pcs to haul. 1-foot pcs will be a bit extra for the cuts. This is great metal for punches or chisels.



Army surplus round nosed pliers that make good scroll pliers for small items. They are 6" long \$5.00 each plus shipping. I also tie brooms on your handle or mine. \$20.00 plus shipping. Diana Davis 580-549-6824 or Diana-copperrose@hughes.net



Wanted:
Advertising Coal Hammers, Contact Mike George at 1-580-327-5235 or o Mike-Marideth@sbcglobal.net

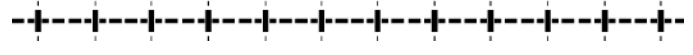

Wanted;
8ft overhead pick-up camper, might accept some needed repair. Contact Fred Hunholz at ...405-737-3627 or hunholz@att.net or fredhunholz@aol.com

Club Coal

Saltfork Craftsmen has coal for sale. Coal is in 1-2" size pieces The coal is \$140.00/ton or .07 /pound to members .No sales to non-members.

NW Region coal location:

Bring your own containers. Contact Tom Nelson at 1-580-862-7691 to make arrangements to pick up a load. **DO NOT CALL AFTER 9 P.M.** If you make arrangement well in advance, Tom can load your truck or trailer with his skid steer loader. Otherwise you will need to bring a shovel. The coal can be weighed out at the Douglas Coop Elevator scales.

S/C Region coal location: Coal is in 1-2" size pieces. Bring your own container. The coal is at Max Scrudder's place in Mountain View. Contact Max for load out instructions. Max Scrudder can be contacted at (405) 226-9951

NE Region coal location: Dan Cowart also has coal to sell. He can be contacted at ddcowart@gmail.com or Cowart-Pat@gmail.com

New shipment of swage blocks now in.
\$80. plus shipping to members.
\$100.00 plus shipping to non-members
Contact Bill Kendall for more information

Send your ads to the Editor by the 20th of each month. Ads will run for 60 days.

MEETING SCHEDULE

Oct.

There are no club meeting scheduled this October because of the annual conference.

Nov.

SE Regional meeting (Nov 7th) Open

NE Regional meeting (Nov 14th) Hosted by Dwayne Moss

S/C Regional meeting (Nov 21st) Hosted by Bill Davis at his home/shop west of RushSprings.

NW Regional meeting (Nov. 28) cancelled

State Fair of Oklahoma

Well, the Fair is only a memory, good or bad. This year was the first one that the Salt Fork Craftsmen have had the opportunity to demonstrate at the fair.



The club members were approached by Melinda Person, a representative of the Fair, at the annual picnic and the membership decided to give it a try. Now we need to hear from all those that took time out of their busy schedule to help at the fair and even those that came by the booth to watch. Many times those that are watching can see where changes could be made or see the fun that they are missing out on.

It took a lot of planning to get everything in place for the first day of the fair. We brought in the trailer on Tuesday and quickly got the permanent items in place. The forges, anvils and swage block stands were left in place each night and only the loose tools and equipment were carried back and forth to the trailer each day.

The Fair provided the demonstrators with free parking and gate passes for each day they were to work. We tried to get three to four to work each day to give each one a chance to check out the events at the fair. Most days we only had to be there at 1:00 but we could come in as early as we wanted and stay as late as we wanted (after 6:30). We were located in the Centennial Frontier Experience which was interesting at times.

Most of the time we couldn't see the acts going on but we could definitely hear them.



Scenes from the State Fair.



Fair continued...

These were just a few of the members that have worked at the Fair. If we are asked and we agree to work again next year, it will take more members to commit. This is not a great money making opportunity (sometimes we only sold enough each day to get something to eat) but it was a great chance to educate the public about our club.

Every given weekend...

It seem like once the temperatures get above freezing there is somewhere to go and demonstrate. This month is no different. On opening day of the fair we also had members in Tulsa at the Ren Faire, Sulphur tractor show, Chisholm trail museum in Duncan and our SC regional meeting in Elk City. Those are just the ones that came into the newsletter. I'm sure that there have been many more.

9/21/09

Northeast Regional Meeting

Danny Cowart

The Pawhuska Chamber of Commerce ask us to join them in Pawhuska at the Blacksmith's house at 210 W. Main. They are interested in building a late 1800 Blacksmith shop with a demonstration area. I decided to move my meeting to Pawhuska and set up behind the original home of the first blacksmith, Sid Delarue that the Osage Indians hired in 1871.

We had a good turnout. There was over a dozen members present plus quit a few visitors.

Mike McCartney, director of the Pawhuska Chamber of Commerce brought in three large tents and set them up to accommodate us and the Osage women that was supplying our lunch. This was also the weekend for the 3rd Annual Osage Film Festival. We had several booths set up by local artists and they were very good. I noticed several people buying some of their work.

The local newspaper showed up and took a lot of pictures. Tracy and Roy Tate demonstrated on our forge. I laid out some of my collection of trade items.

At 10: 00 most of the blacksmiths went to the Bronze Horse for a tour. It turned out to be a very good tour. John Free and his wife always like to show people what they do. They were doing a statue of Ben Johnson roping a steer from the back

of a horse in full size. All the feedback was very positive of the tour.

The group got back around lunchtime and the Osage women had it ready. It was an Indian meal with fry bread, meat with grape sauce with green beans.

I am going to try and get this Blacksmith shop built and thank all who are and have contributed to it. The next stage is to see if they can get the money and material. Thanks

Dan Cowart

Scenes from Sulphur Tractor Show....

The club has been participating in the Sulphur tractor show for several years. This year with everything that was going on that weekend it looked like the club was going to have to pass on this years event but Byron Doner, Kent Doner and Richard Simpson covered the event on Friday and Bill Davis joined them for Saturday. Kent was the photographer for the event. *I would like to personally thank Kent for providing the photos. DD*

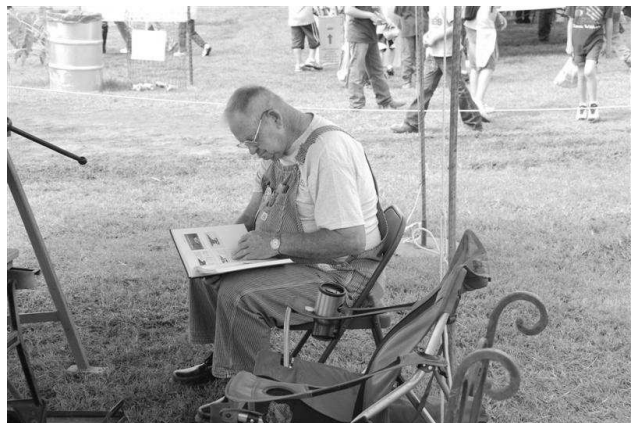

More scenes from Sulphur...



President's Notes

Gerald Franklin

Boy, what a month. There has been a whirlwind of smithing activity around the state during September. We Saltfork folks have supported tractor shows, community activities, the Oklahoma State Fair, and our customary regional meetings all while continuing to prepare for the 13th Annual Conference in Perry on October 17-18.

The biggest effort was our support of the Oklahoma State Fair where we provided over 400 man-hours (person-hours (?)) of demonstration, set-up, and tear-down time. This is probably the biggest event in terms of long-term club wide involvement that we have ever undertaken. Eleven straight days of demonstrations gave us the opportunity to interact with a large chunk of the Oklahoma population. Many of our members gave up a lot of their otherwise free time to go to OKC to help wave the Saltfork flag. When you see them around, give them your thanks because they certainly deserve it. You particularly need to thank Diana Davis and Aniela Hadick for their effort in coordinating the entire State Fair demonstration.

The 13th Annual Conference is right over the horizon and it is shaping up to be a real winner. We will provide one of the few opportunities to see all three Gunters: Robb, Brad, and Chad demonstrating at the same event. You don't want to miss this one so send your registration in now. Early registration helps us with meal planning and other support items as well. If you can spare the time, come up early and help with the set-up of the Noble County Fairgrounds facility. Also, plan to bring a few donation items for the Iron-in-the-Hat raffle and the auction. As always, we'd like to see some of your work displayed in the Gallery.

See you there.

We need folks to help sell tickets. If you would like to help please call or email and I'll mail you some.
David Seigrist, (call) 580-381-0085 , or (email) dseigrist2004@yahoo.com

SCABA TOOL BOX AND TOOLS for 2009

Tool/Item	Maker/Buyer	Cost/Value
Box	JC Banks	
Hardware for toolbox	Mike George	
Cross peen hammer	Clay Reamy	
Straight peen hammer	Clay Reamy	
Rounding hammer	Clay Reamy	
Tongs:		
1/4 v-bit	Clay Reamy	
3/8 v-bit	Clay Reamy	
1/2 v-bit	Clay Reamy	
3/4 v-bit		
1/4 flat	Clay Reamy	
3/8 flat	Clay Reamy	
1/2 flat	Clay Reamy	
3/4 flat		
Scrolling		
Side grip	Reamy	
Pick up tongs	Reamy	
Fire tools (Shovel, rake, poker)	Reamy shovel and poker	
Hot cut hardie		
Cold cut hardie		
Twisting wrench	Diana Davis	
Treadle/Hand Hammer Tooling	JC Banks	
Set of punches and holder		
Center punch		
Chisel, large		
Chisel, small		
Chisel, hot slit		
Slitting chisel		
Hold Down	Dan Cowart	
Flat wire brush w/handle		
File, flat bastard cut w/handle	Doug Bliss	
File, half round w/handle		
Set of monkey tools		
Rivet backing tool		
Rivet setting tool		
Hacksaw	Maurice Hamburger	
Bolster plate		
Square	Maurice Hamburger	
Dividers/Compass	Maurice Hamburger	
Scribe		
Bending forks		
Spring swage (necking down)		
Flux spoon	Jim Carothers	
Metal folding ruler 24" or 72"		
Soapstone	Diana Davis	
Ball tool (round blunt nose punch)		
Hook Ruler		
Iron Mountain Flux	Jim Carothers	
Finishing Wax + Borax	Linda Bliss	
Nail Header	Dan Cowart	
Dual Caliper		
Total value to date:		

The toolbox inside dimensions are 25" long and 11" wide.

SCABA Workshops

Title:	Date:	Instructor:	Location:	Status:	Cost:
Repousse	6 – 9 Nov 4 day workshop	Mark and Mindy Gardner	Altus, OK	4 open seats	\$218
Power Hammer Use and Tooling	14 Nov 09	Richard Dyer	Tulsa, OK	3 open seats	\$ To be deter- mined

Power Hammer Use and Tooling:

Richard Dyer from his many years of experience as a professional blacksmith will show us some of the tooling and techniques he uses in commercial production of forged items with the use of a Little Giant power hammer.

Repousse/Chasing Workshop – Only 4 seats left.

We are up to 8 folks enrolled in the class so far, that means the price is down to \$218! The class will be held in Altus, OK from 6 – 9 November, that’s a Friday thru Monday. If 12 signup, the cost would be about \$145 per person, plus meals and lodging.

The first day will be tool making and the next three are repousse work. Mark will be bringing special treadle hammers that are very helpful with this kind of work. The treadle hammers will be for sale at \$1,350 each after the workshop. Buying a treadle hammer isn’t required, he brings them for the students and if you want to purchase one he’ll sell it. Their website is www.floodplainforge.com.

The more students we have the less it costs:

9	\$195	10	\$175
11	\$160	12	\$145

Plus your meals and lodging

To sign up for any of these workshops call or email and then send a check to me.

David Seigrist
P.O. Box 163
Hollis, OK 73550
(580) 381-0085 dseigrist2004@yahoo.com

Western Spirit Celebration – 2009

Gerald Franklin

The 2009 Western Spirit Celebration was held at the Chisholm Trail Heritage Center in Duncan, OK on September 19-20, 2009. Jerry Cathey and I set up our portable forges on Saturday morning just in time for the rain. After a couple of hours of pretty steady rain, the run-off forced us to move our rigs up the hill to get out of the mud. The good news was that all the rain fell before the opening ceremonies so we were able to get re-located before the crowds showed up.

This event was well attended and sales were pretty good. In addition to our forge set-ups there were 8-10 chuck wagons competing for in several food categories. One of the best things about supporting this event is that Jerry and I always get fed at these top-notch wagons.

We were pleased to see a steady flow of people coming by to watch the forging and listen to our lines of “bull”. We passed out several newsletters and membership forms throughout the weekend so maybe there will be a few more members join up.

Sunday was more family/kid oriented than Saturday. Vendors came in early Sunday and set up kiddie rides before the “Cowboy Church” service. After the service, kids moved around the area taking it all in. We were pretty well swamped with families all day Sunday as kids and their parents/grand parents were very interested in the smithing demo.



If you have never been to the Chisholm Trail Heritage Center in Duncan, you need to plan a trip to tour the small but very well done museum. It opens at 10 AM daily.

NORTH EAST REGIONAL MEETING DATES

January 10, 2009
Host: Gary Gloden

February 14, 2009
Host: Bill Kendall

March 14, 2009
Host: Dan Cowart

April 11, 2009
Host: Open Easter Weekend
Phone #:

May 16, 2009
Host: *State meeting*
Phone #:

June 13, 2009
Host:
Phone #:
Trade item:

July 11, 2009
Host: Mike Sweany
Phone #:

August 8, 2009
Host: Omar Reed at Fort Gibson
Phone#
Will be working on hinges

Sept. 12, 2009
Host: Dan Cowart (Pawhuska Blacksmith shop)
Phone #:
Trade item something Indian, (feather, leaf, etc.)

October 17-18, 2009
SCABA Conference

November 14, 2009
Host: Dwayne Moss
Phone #:
Trade item

December 12, 2009
Host: Charlie McGee
Phone #:

NORTH WEST REGIONAL MEETING DATES

January 24, 2009
Host:

February 28, 2009
Host: Ron Lehenbauer

March 28, 2009
Host: Bob Kennemar
Phone #:

April 25, 2009
Host: Mike George
Phone #:

May 16, 2009
Host: State meeting –No regional meetings
Phone #:

June 27, 2009
Host:
Phone #:

July 25, 2009
Host:
Phone #:

August 22, 2009
Host:
Phone #:

Sept. 26, 2009
Host: Gary Seigrist (Elk city)
Phone #:

October 17-18, 2009
SCABA Conference

cancelled November 28, 2009
Host: Mandell Greteman
Phone #: 580-515-1292

December 26, 2009
Host:
Phone #:

SOUTH CENTRAL REGIONAL MEETING DATES

January 17, 2009

Host: JC Banks

Phone #

February 21, 2009

Host: Gerald Franklin

Phone #:

March 21, 2009

Host: Terry Jenkins

Phone #

April 18, 2009

Host: Bob Kennemar

Phone #

May 16, 2009

Host: State picnic at Norman

No regional meetings

June 20, 2009

Host: Anelia Hadick

Phone #: 1-405-406-3705

July 18, 2009

Host: Max Scrudder

Phone #: 1-405-226-9951

August 15, 2009

Host: Richard Simpson

Phone #: 1-405-344-7413

Sept. 19, 2009

Host: Dorvan Ivy (Elk City Museum)

Phone #: 1-580-473-2761

October 17-18, 2009

Host: : SCABA Conference Perry, Okla.

November 21, 2009

Host: Bill and Diana Davis

Phone #: 580-549-6824

December 19, 2009

Host: Anelia Hadick

Phone #: 1-405-406-3705

SOUTH EAST REGIONAL MEETING DATES

January 3, 2009

Host: Howard Bost

Phone #:1-903-785-0864

February 7, 2009

Host: Howard Bost

Phone #: 1-903-785-0864

March 7, 2009

Host: James Allcorn

Phone #:

April 4, 2009

Host: Howard Bost

Phone #: 1-903-785-0864

May 16, 2009

Host: State meeting in Norman Ok

June 6, 2009

Host: Mark Hammell

Phone #:

July 4, 2009

Host:

Phone #:

August 1, 2009

Host: Omar Reed at Fort Towsan historical site

Phone #:

Sept. 5, 2009

Host: open

Phone

October 3 2009

Host: SCABA Conference Perry , Okla

Phone #:

November 7, 2009

Host: open

Phone #:

December 5, 2009

Host: open

Phone #

13th Annual Saltfork Craftsmen Blacksmithing Conference

Registration

October 17 & 18, 2009

PLEASE PRINT CLEARLY

NAME: _____ SPOUSE NAME: _____

ADDRESS: _____

PHONE: _____

E-Mail: _____

Conference Registration Fee (One per family). Membership required for attendance. Charge for non-members is \$10 for membership until March 31, 2010.			
	Number	Cost Each	Total
Saturday & Sunday (per family)		\$55.00	
Saturday only (per family)		\$35.00	
Sunday only (per family)		\$35.00	
Membership until 3-31-08 for Non-Members		\$10.00	
Meals			
Saturday Lunch (per person)		\$6.50	
Saturday Supper (per person)		\$11.00	
Sunday Lunch (per person)		\$7.50	
Family Classes on Saturday - Limit of 10 students per session			
9:00 AM-Stained Glass (butterfly suncatcher)- Diana Davis		\$10.00	
10:00 AM-Silver wire ring, wire & beads supplied - Teresa Gabrish		\$10.00	
2:00 PM-Sewing Class(cloth shopping bag) Supplies Provided-Carol Donor&Carol Cable		\$10.00	
3:00 PM-Silver wire work (pendant) - Teresa Gabrish		\$15.00	
Total Payment Enclosed			

Only one Registration Fee required per family. (All meals and all material costs for Family Classes must be paid). Saltfork Craftsmen T-shirts will be available at the conference for \$15.00.

Payment Method (Check one): Check Money Order
 Make checks payable to **Saltfork Craftsmen ABA.**

Address correction:
 9911 N. 117 E. Ave
 Owasso, Ok 74055

Mail this form with full payment to: Tammy Cowart
 9911 N. 1117 E. Ave.
 Tulsa, OK 74055

All adults attending the conference must sign this Disclaimer. Parent or legal guardian must sign for minor children.

Disclaimer: I understand that blacksmithing can be a dangerous endeavor. I understand that my safety is my responsibility. I understand the need for eye and ear protection; I will provide and utilize the necessary safety equipment for all activities. The Saltfork Craftsmen ABA, its officers and members are not responsible for my well-being. Registration for the Conference indicates my agreement to these terms.

Signed: _____

Date: _____

Signed: _____

Date: _____

Signed: _____

Date: _____

This side left blank on purpose.
That way you have no excuse for not tearing it out and sending in your
conference registration.

NW Regional meeting...SC Regional meeting

Both the NW and the SC regional meeting were held at the Route 66 museum in Elk City. Dorvan Ivy and Gary Seigrist were the host. I didn't get to attend the meeting on the 19th but did make it up there for the NW regional meeting on the 26th. They had a fair turnout for the meeting but that was alright it just left more of the grilled burgers for the rest of us.



The trade item was a cooking utensil. This one that was made during the meeting. It is a bread toaster for use at a campfire.



Doug Merkel on Collars (This was from Doug's write-up of his scholarship class.)

See also page 15 of this issue for Alan Kress's swage for decorating collar stock.

Collars are one of the traditional methods of fastening parts of an iron project together without welding, rivets or bolts. It is relatively fast, not very difficult, looks great when finished, and holds much tighter than you may expect.

Collars: In our example we are joining two 3/8" x 1" scrolls to opposite sides of a 1" sq. support. The collar stock we are using is 1/4" x 1". Fig 1

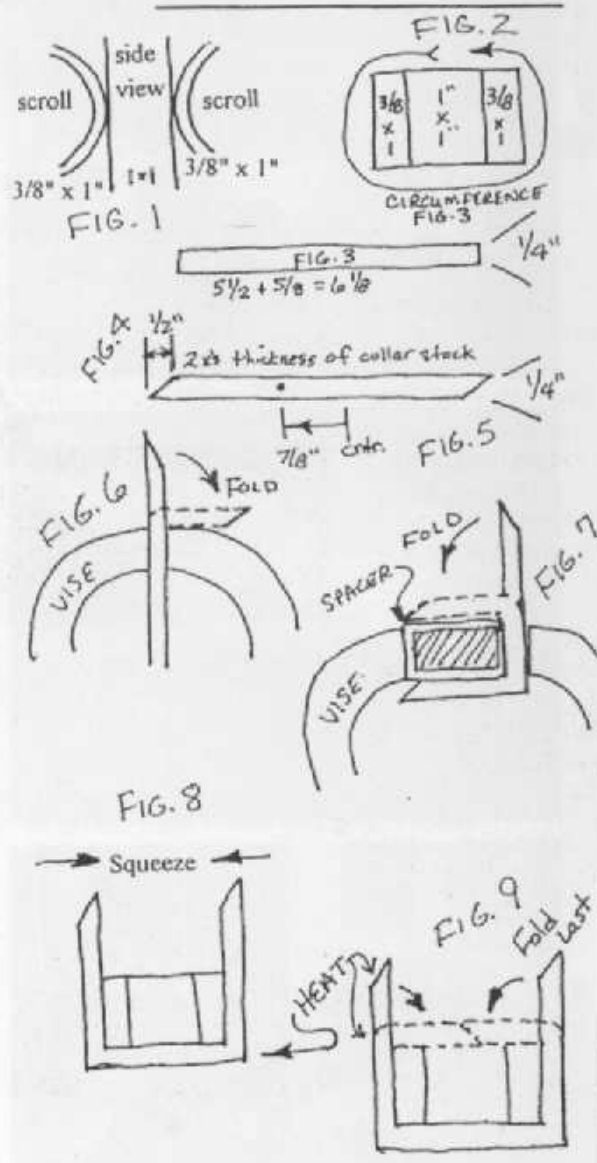

- 1) Figure out the length of collar stock you need.
 - a. measure jointly around the the pieces to be collared. (circumference = 5 1/2") Fig. 2
 - b. Use the formula to calculate collar length. The length will be the same for collars that overlap or butt together. Fig. 3
 C = circumference
 S = 2 1/2 x collar stock thickness (1/4").
 (so, S = 2.5 x .25 , S = .625 or 5/8")
 L = Length of stock needed.
 - c. Formula: L = C + S (6 1/8 = 5 1/2 + 5/8)

- 2) If you wish for your collar to overlap now is the time to bevel the ends. Do not quench - because you will be cold bending.
 - a. Bevel each end, opposite directions, taper length should be 2x's the collar thickness. (1/2") Fig. 4
- 3) Find center of collar and locate point of first bend.
 - a. point is located by subtracting 1/2 the width of the front pieces you are going around, from the center of your collar.
 (center - 7/8" = bending point) Fig 5
- 4) Bend (cold) at point, 90, using post vise. Fig. 6
- 5) Bend again, in vise, using a spacer block that is the same width as the front of the pieces you are going around. (1 3/4") Fig. 7
- 6) With work piece now up side down, set the collar in place using a set hammer or stock to back up the joint so all pieces will bottom out into collar. Heat lower corners and squeeze together using large tongs. Fig. 8
- 7) Heat and bend remaining ends, using sliding blows with a cross peen. Be sure you bend them in the correct order if they are overlapping. Excess hammering will only spread the collar so keep it to a minimum. Allow to air cool as you do other collars. Fig. 9

Reprinted from Hot Iron Sparkle, Vol. 23, No. 2

Bill Fugate's Collar Jig

Here are some pictures of the collar clamp. Also included is a shot of a "Boyd Holtan" trivet. The clamp is intended to sit atop the vise jaws. The collar is set in the clamp and heated cherry red. The trivet is then set in the collar and vise tightened to close it. The ends of the collar are then closed over and set tight with a hammer.

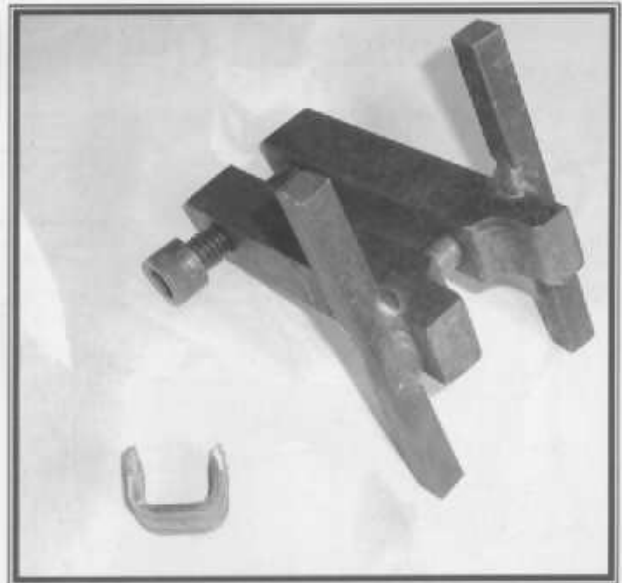

I've made 20 or more trivets like this for gifts and as a result have a whole set of jigs to speed up the process. I've always fought the collars, so I recently made this collaring jig. Now I can install three collars in about 5 minutes.



Francis Whitaker's Collar Formula

To collar SQUARE or RECTANGULAR shapes:

Add perimeter of material being collared plus 2-1/2 times the thickness of the collar material.

To collar ROUND shapes:

Add diameters of material being collared plus 3 times the thickness of the collar material.

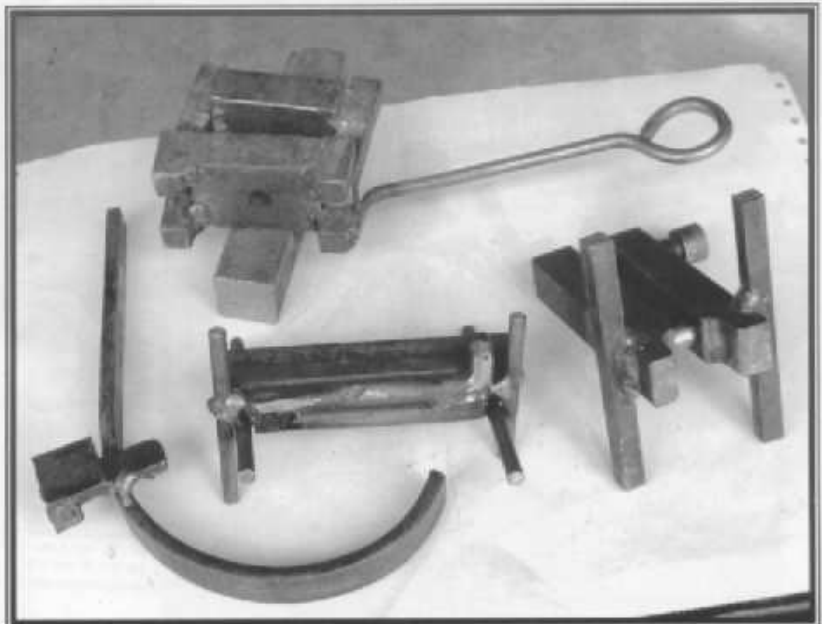

SCABA Workshops....

I've been looking at next years calendar and noticed that there are 4 -5th Saturdays in 2010.

January 30th
May 29th
July 31st
October 30th

These dates are perfect to hold workshops on because they don't interfere with the regional meetings.

Now is the time to be setting up those workshops. One possible workshop for January is an anvil repair workshop. What we need is input from the membership letting us know what kind of workshops to plan for this year and in what region to have host it. Please send in your workshop request along with date and location to David Seigrist. He is the workshop coordinator and will make the final decisions using the information sent in to him. Cost of workshops is dependent of the instructor, materials and number of participants.

Help needed at the conference....

Dan Cowart is the conference coordinator and he has asked that I put a request in the newsletter for help during the conference. There are three positions that need to be filled by membership.

Dan needs two men to help the demonstrators. These two would help tend the fires and help the demonstrators with anything they need.

The other position is with registration. Tammy has requested someone to help out and relieve her so she can take some of the women's' classes.

Don't forget to send in your conference registration...

Don't wait to register for the conference at the conference. We need meal counts ASAP so we can get everything finalized with the caterer.

The instructors for the women's classes need to know how many would like to take the classes. Kits and supplies need to be purchases.

Support your organization by bringing item for the iron-n-the-hat drawings and auction. You can also display your works in the gallery. Bring your items for the auction and gallery to the women's building, take your iron-n-the-hat items to the registrations building when you check in.

You will need safety glasses to enter the demonstration area. Make sure you bring a pair or be prepared to purchase a set.

Deco Clock

M. Hamburger
10-07

Materials

$\frac{1}{4} \times 1\frac{1}{4}$ " 16" long

$\frac{3}{8} \times 1\frac{1}{2}$ " 13" "

$\frac{1}{8} \times 4$ " material

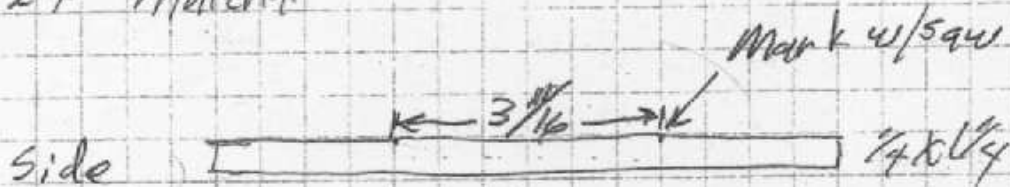

In center of $\frac{1}{4} \times 1\frac{1}{4}$, layout $3\frac{1}{16}$ " in center of Bar.

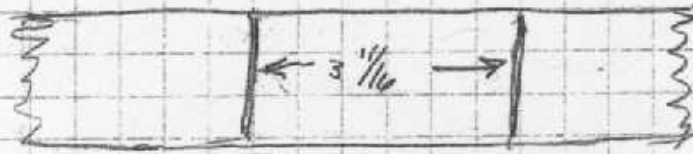

Mark w/hammer, as square to edge (side) as possible

Note
Thickness (width) of tool to forge channel will affect the distance between the two legs

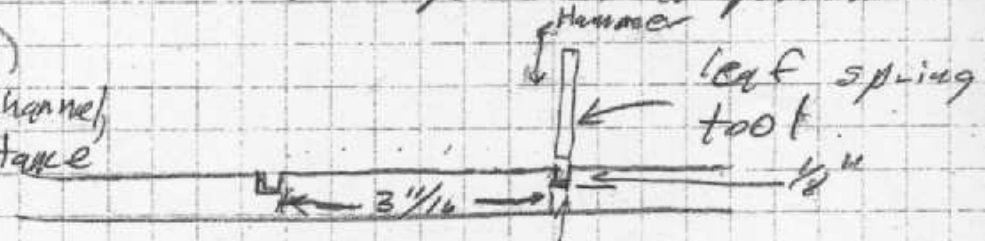

Forge channels $\frac{1}{2}$ way through $\frac{1}{4}$ " material, use $\frac{1}{4}$ " spacers to stop leaf spring tool.

Triettle hammer work good for this.

Deco Clock

2

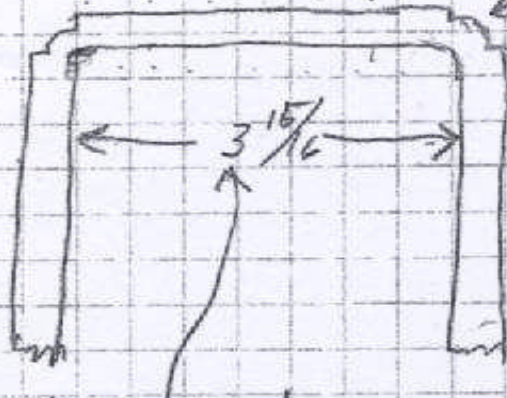

Bend each leg 90° to form "U" shape. Make corner as square as possible and All three side of "U" on the same plane

This distance will vary depending on the width of your tool (leaf spring)

Cut 2 pieces $\frac{1}{8} \times 4$ " the length of the space between the two legs. $3 \frac{15}{16}$ "

File, grind/sand to get 2 pieces to fit in "U" shape frame.

lay out Clock Face on one $\frac{1}{8} \times 4$ "

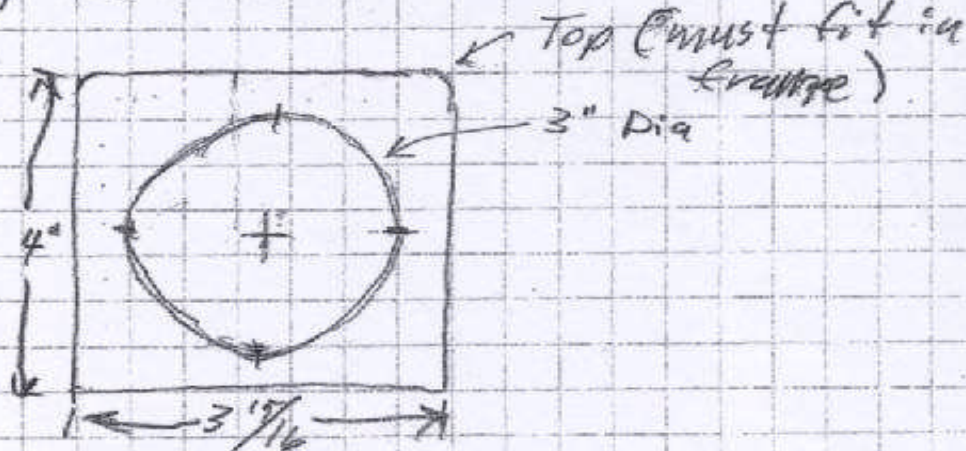

Maybe different length, should be close to 4", could be over 4"

Peco Clock

3

For 1, 2, 5, 7, 8
10, 11 positions
use small square
punch ($\frac{1}{8}$ " square on
end) and hot punch
small indentation onto
plate.
(Note - try to keep
square punch square
with 4×4 plate)



$\frac{5}{16}$ " hole for
quart clock movement.

For positions 12, 3
6+9 use common
nail, (Large Head)
Forge/grind/sand
Head square.
or use use small
screw or Bolt with
head forged square
and flat. 5mm bolt
 $\frac{1}{4}$ -20 Bolt.

Drill holes for
12, 3, 6+9 large
enough for nail or
bolt to go through.

Heat both plates ($3\frac{1}{2} \times 4$) in forge
to attain fire scale texture,
wire brush. Insert Nail Head or bolt
heads cut to length & rivet on
inside, if using bolt can drill & tap
hole & screw in. Try to keep square
Nails or Bolt heads square w/ plates.

Position
Plate slightly back
 $\frac{1}{8}$ " from front of
Frame

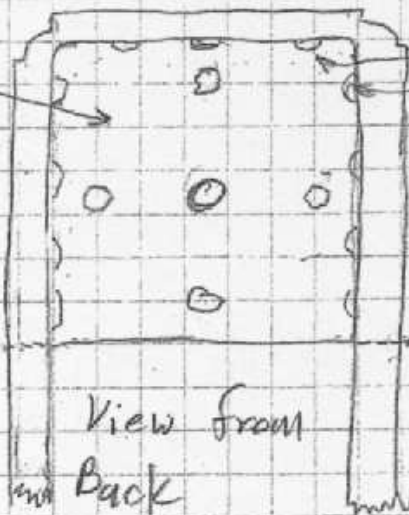

Weld plate
to inside of
"U" shape

Cut off, Bandsaw
chop saw, excess

View from
Back

Deco Clock

4

Base Plate

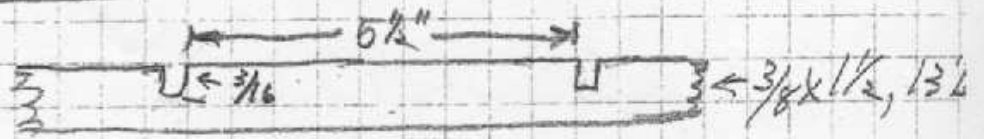

Lay out 5 1/2" in center of 3/8 x 1/2" bar, forge channels 1/2 way through bar, same procedure used on 1/4" thick material, bend legs 90° and cut legs, 1" or 1 1/2" long.

1/2" \square welded in center, drilled & Taped for 8-32, 10-32 screw to hold back plate. Back plate s/o. even with back of frame (box)

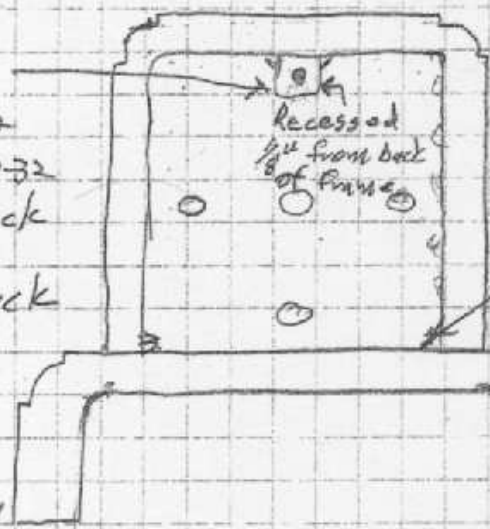

Note Back Plate not necessary but covers all those ugly welds and needs to be removable to replace battery.



This length could be shorter
Drill hole for 8-32, 10-32 screw to pass through to attach back plate

finish as Desired

Saltfork Craftsmen

Artist-Blacksmith Association
Membership Application
April 2009 thru March 2010

Please accept my application

Date: _____

First Name _____ Last Name _____

Married? Yes No Spouses Name _____

Address _____

City _____ State _____ ZIP _____

Home Phone (____) _____ Work Phone (____) _____

E-Mail _____ ABANA Member? Yes No

I have enclosed \$20.00 for dues to March 30, 2010

Signed _____

Return to: Saltfork Craftsmen, 1227 Fourth St. Alva, Ok 73717



Name: _____

Email: _____

Address: _____

www url: _____

City: _____

Phone: _____

State: _____ Zip: _____

Fax: _____

Country: _____

TYPE OF MEMBERSHIP:

CREDIT CARD INFORMATION:

NEW MEMBER RENEWAL

VISA Mastercard Expiration Date: _____

Regular - \$55.00 Contributing-\$100.00

Card Number: _____
Submit check, money order -U.S. Banks only, or by credit card:

Student- \$45.00 Library-\$45.00

Senior (65+) \$50.00 Foreign-\$65.00

ABANA Chapter Affiliation: _____

PO Box 3425
Knoxville, TN 37927-3425
Phone: 865.546.7733 Fax: 865.215.9964

Saltfork Craftsmen Artist Blacksmith Assoc.Inc.
1227 Fourth Street
Alva, Okla. 73717-1227

U.S. POSTAGE PAID
STERLING, OKLA
NONPROFIT
ORGANIZATION
73567

Address Service Requested

